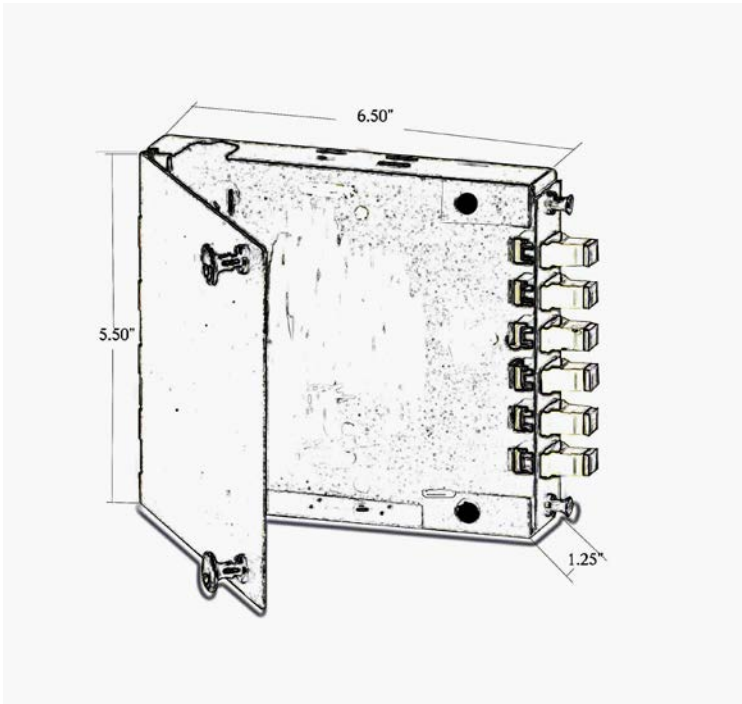

**Re: WXL Series Wall Mount Fiber Optic Enclosures****Specifications: Part No. WXL-1 Fiber Optic Wall or Din Rail Mount Enclosure****(Document No.019008) 02-27-19 Rev.1 Note: Specifications subject to change without notice.**

Part Number	Description
-------------	-------------

**WXL-1**      **One Module Fiber Optic Wall Mount Enclosure**  
Accepts: 1ea. LGX-118 Type Fiber Optic Insert Modules and up to 2ea. 6 Fiber Fusion Splice Holders.  
2ea. MTP Cutouts, Din Rail Mount Option (Left Side)  
Dimensions: 5.50" H x 6.50" W x 1.25" D  
Weight: 2 lbs. Approx.

**Features**

- USA Made (16 Ga. Steel)
- Durable Epoxy Powder Coated Finish (Black)
- 1 Fiber LGX-118 Type Insert Module
- Top and Bottom Cable Entry
- Fiber Management Spools or Wire Saddles
- Thru hole locking front door feature for padlock
- Continuous left side hinged front door
- Accommodates 2ea 6 fiber Fusion Splice Holders